



Facility Management Guide

Updated:
Next review:

November 2020
November 2021



Table of contents

1	Purpose	1
2	Part 1 – developing or improving an existing facility	2
	The basic	2
	Legal obligations	2
	Identifying client needs.....	2
	Improving access	3
	Personal safety.....	3
	Lighting.....	4
	Avoiding danger spots.....	4
	Changing rooms and toilets	5
	Signs.....	5
	Maintenance.....	5
	Childcare	6
	Social activity.....	6
	Atmosphere	6
	Part 2 – Softball specific	7
	Diamond specifications	7
	Playing field measurements.....	7
	Equipment measurements/standards	8
	Official dimensions for Softball diamonds.....	9
	Base, plate and batters box measurements	10
	Softball lighting specifications	11
	Diamond upkeep	11
	Equipment/tools for diamond maintenance	11
	Suggested safety checklist (performed daily or before games/use)	12
	Create a high performance skinned infield	12
	Clean the infield.....	12
	Outfield grass	12
	Infield dirt.....	12
	Suggested field maintenance routine	13
	Daily maintenance routine before training or use.....	13
	Daily maintenance routine after training/use	13
	Game day checklist – field of play	13
	Game day checklist – operational.....	13
	Watering the diamond	13
	Turf maintenance	14



1 Purpose

- 1.1 This Guide has been designed to help softball providers within Australia (including state and district associations, clubs and recreational organisations) develop and maintain a safe, enjoyable and productive softball facility. The first section of this Guide provides general information on developing/setting up a sporting facility and covers areas such as location, accessibility, signage, venue lighting, safety and social provisions.
- 1.2 Part 2 – Softball specific deals with softball specific information, with material being sourced from the Softball Australia and WBSC Official Rules of Softball and the WBSC Technical and Procedural Manual. This section will cover topics such as regulations, on diamond dimensions and measurements, diamond lighting standards, diamond maintenance, surface standards and facility layout etc.
- 1.3 Softball Australia hopes this Guide will assist you in the development and maintenance of a softball facility.



2 Part 1 – developing or improving an existing facility

The basic

- 2.1 A well-designed sport or physical activity facility attracts people and encourages them to use it. The way a facility is managed, and its atmosphere can either encourage or discourage people's active involvement in sport or physical activity. Service providers can increase their membership and participation revenue by addressing these issues, so they more adequately meet the needs of their clients and prospective clients.
- 2.2 Providers of physical activity programs should be receptive to both the needs of clients and the relevant legislative requirements when using, designing or modifying a facility.

Legal obligations

- 2.3 It is important that facility structures and equipment comply with laws, regulations, rules and standards. Local councils can provide information about current legislative requirements. Facilities are required to be designed in accordance with the Building Code of Australia and the relevant Australian Standards.
- 2.4 Service providers should be aware of their obligations under current legislation and select or design facilities accordingly. In addition, they should consider how well the design, construction and maintenance of a facility complies with the relevant standards.

Identifying client needs

- 2.5 Service providers are responsible for establishing the best possible environment in which people can be physically active. They should ask their clients where they would prefer the sport and physical facility to be, and what safety needs, access requirements and other factors influence their choice of facility and therefore their participation. Consultation with clients will help providers meet the needs of an increasingly diverse community.
- 2.6 Consultation processes may include:
- questionnaires
 - individual interviews
 - focus groups
 - forums
- 2.7 Assistance with consultation processes can be provided by state and local government officers involved in planning and development issues. It is also important to consider the needs of potential clients in the consultation process and the special needs of particular groups, for instance, people with children, people who don't speak English confidently, or people who have work or family commitments at particular times. Because women are under-represented in sport and physical activity in Australia, it is particularly important for providers to understand and cater for their special needs, so that more women will take part in future.

3.4 Choosing the right location

- 2.8 Providers should consider the following factors when selecting a site or venue for sport, recreation and physical activity. Generally, in terms of safety and accessibility, a well-located facility will be:



- on land of appropriate size and aspect
- close to adequate, regular public transport (bus, train, tram, taxi and ferry)
- close to safe pedestrian and cycling networks
- situated in areas of high public use
- close to shops and other services
- surrounded by suitable land use and not physically isolated
- perceived positively by the community
- well maintained
- close to existing and potential clients
- designed to provide opportunity for natural surveillance
- located in an area that has provision for long-term expansion
- in an area that has available and appropriate infrastructure
- easily accessible by emergency services (ie police, ambulance, fire brigade)

Improving access

2.9 Clients have varying needs that must be satisfied to ensure their easy and equitable access to sport and recreation services. Providers should ensure that the facility selected caters for all members of the community, including those with restricted mobility, and has:

- a car park with adequate spaces, that is close to the facility entrances and is easy to find and enter
- clearly marked car spaces for disabled people and carers with prams
- well lit, smooth paths between the car park and the building entrance for wheelchair and pram access
- ramping throughout the facility to ensure that people with disabilities, elderly people and carers with prams have easy access
- nearby access to police and emergency services (including medical services)
- unrestricted access for emergency services (gates should be locked for security but easily unlocked in emergencies)

Personal safety

2.10 Community concerns about personal safety affect the way people participate in all aspects of daily living. If they feel uncomfortable or unsafe they may be deterred from taking part in sport and physical activity. Sport and recreation venues of all sizes can put simple and effective safety measures in place that will benefit both clients and staff. These include:

- ensuring regular surveillance of the facility by local authorities or security guards to prevent potential crime
- providing adequate staffing of the facility (at least two staff present at all times – if appropriate)



- fitting security devices (locks, grilles, alarm systems and security cameras) that do not prevent exit from the building in case of emergency
- displaying prominent notices, both inside and outside the facility, stating that drugs are not permitted, nor kept on or near the premises
- ensuring public telephones are available, accessible and well-maintained, both inside and outside the facility
- ensuring access to help from nearby facilities if it is needed
- limiting noise in the area (so that clients and staff can be heard if in trouble and trying to attract assistance)
- establishing evacuation procedures and ensuring easy access to emergency exits and stairs

Lighting

2.11 Appropriate lighting of sport and physical activity facilities is a significant, low-cost way of preventing people, particularly women, children, people with disabilities and the elderly, from feeling vulnerable at night. Service providers should ensure that:

- adequate lighting is provided in the facility car park, at entrances and exits, and on paths and surrounding streets
- bus shelters, benches and seats are well lit
- lighting is adequate in sheds, toilet blocks and unlocked empty rooms

2.12 there is adequate lighting to safely participate in the activity (in accordance with the Australian Standard for Sports Lighting [AS 2560.1-2002](#) – see Part 2 – Softball specific for lighting specific to softball):

- outside lights have a timing device or a light-sensitive switch so that they turn on automatically
- vandal-proof lighting is used to minimise ongoing maintenance
- trees and bushes do not conceal lighting

Avoiding danger spots

2.13 Small, confined areas, such as lifts, storerooms, fire stairs, empty unlocked rooms, dark recessed entrances, gaps in tall shrubbery, parking lots and isolated sections of a building can become danger spots for vulnerable passers-by. Such areas can hide potential assailants, particularly at night. Providers should check that:

- appropriate landscaping is used (minimising concealing shrubbery)
- surrounding planting is well lit and does not obscure lighting
- planting provides no potential hiding places
- trees or other climbable objects are not close to fences
- potential entrapment areas that cannot be improved are well lit and/or alarmed



Changing rooms and toilets

2.14 The design and standard of changing rooms affects the extent to which people will use them. Appropriate change facilities offer privacy and an adequate number of showers and toilets. Good changing and toilet facilities have:

- toilet and shower doors that shut and latches that work
- outward opening doors to prevent obstruction if a person is on the inside and needs assistance regular care to keep them clean, tidy and hygienic
- prominent notices encouraging the use of showers and toilets before and after activities
- rubbish bins in changing areas
- shower and changing facilities that cater for privacy needs
- comfortable mothers' rooms and baby change facilities
- lockers available at low or no cost
- provisions for families to change together so that parents can look after young children
- separate men's and women's toilets
- toilet and change facilities for people with disabilities

Signs

2.15 It is important that the facility has clear and accurate signs so everyone has easy and equal access. Ensure that:

- all signs are well positioned, visible and well lit
- entrances and exits are clearly marked
- street signs are provided
- significant signs are illustrated to assist children and other community members to understand meanings
- signs are provided in other languages if and where necessary

Maintenance

2.16 The appearance of a facility, including its cleanliness, will affect the way clients feel about it and therefore how much they use it. The swift removal of rubbish, graffiti, and other signs of vandalism will help people feel more comfortable when participating in activities. It is also vital for the safety of all those using the facility that surfaces, fittings, equipment, air conditioning and grounds are maintained regularly and thoroughly. A well maintained facility has:

- a maintenance plan and an inspection program
- good general maintenance and cleaning (ie no broken fences and light bulbs and no rubbish lying around)
- areas used for physical activity that are in good and safe condition
- children's play areas attached to the facility that are in good and safe condition



- a process or system to ensure that litter, graffiti and signs of vandalism are quickly removed and any damage repaired

Childcare

2.17 Childcare facilities and services at sport and physical activity centres make it easier for people caring for young children to be involved in the activities. Service providers designing, modifying or selecting a facility should think about:

- evaluating and monitoring the quality of the current childcare facility and service
- taking the opportunity to design an appropriate facility and service that meets legislative requirements and client needs
- ensuring compliance with the requirements of legislation and regulations relating to the provision of childcare

Social activity

2.18 The social aspect of sport and physical activity is important. Many participants continue being involved in physical activity for the social benefits. Providers should consider whether their facility offers:

- areas inside and outside where clients can socialise before and after using the facility
- an adequate and affordable range of food and drinks, perhaps a sectioned bar area

Atmosphere

2.19 The atmosphere of the facility will have a significant effect on membership, client satisfaction and staff morale. If the facility is well maintained and provides a friendly, open atmosphere, most people will feel good about using it. When assessing a facility, service providers should consult with clients and staff, especially women and other target client groups and invite them to participate in the assessment. They should ask clients for their initial feelings about the facility and how the atmosphere might be improved.

A sport and physical activity facility that is welcoming for all community members will:

- employ staff who are friendly and approachable
- provide childcare facilities at minimal cost and adopt a child-friendly approach
- ensure women get an equitable share of the equipment and facilities
- have sessions for women only, or sessions that cater for the needs of special groups (eg those with specific cultural requirements or older people)
- employ appropriately qualified female instructors
- ensure that female staff are on duty for female-only sessions
- allow female-only sessions at times which offer maximum safety (eg not late at night)
- have considered use of mirrors and glass walls that are placed to protect privacy



- ensure that the facility's layout prevents unwanted attention being paid to clients, particularly women
- have appropriate pictures or images displayed throughout the facility
- ensure the interior design of the facility is comfortable (ie the use of colour, furniture and standard of fittings is appropriate)
- be aware of research that has identified body image as a major factor leading to eating disorders amongst women and encourage sensible exercise and eating practices
- provide up-to-date information specifying exercises and exercise machines that are suitable for women and other members with special needs.

2.20 Please check your state's department of Sport and Recreation for additional information on facility development and management.

Part 2 – Softball specific

Diamond specifications

2.21 The following information has been sourced from the 2014-2017 Official Rules of Softball.

Playing field measurements

FP = Fastpitch SP = Slowpitch	Metric	Imperial
FP Female – home to outfield fence	67.06 m	220 ft
FP Male – home to Outfield fence	76.2 m	250 ft
SP Female – home to outfield fence	83.82 m	275 ft
SP Male – home to outfield fence	91.44 m	300ft
FP/SP male-female – home to backstop (min)	7.62 m	25 ft
FP/SP male-female – home to Backstop (max)	9.14 m	30 ft
FP/SP – home to 1 st base (except Male SP)	18.29 m	60 ft
SP male – home to 1 st base	19.81 m	65 ft
FP female – home to pitcher's plate	13.12 m	43 ft
FP male – home to pitcher's plate	14.02 m	46 ft
SP female – home to pitcher's plate	14.02 m	46 ft
SP Male – home to pitcher's plate	15.24 m	50 ft
FP/SP M/F – (except M SP) home to 2 nd base (18.3m bases)	25.86 m	84 ft.10 in
SP Male – home to 2 nd base (18.3 m bases)	28.07 m	91 ft. 11in
FP/SP – One metre line	0.91 m	3 ft
FP/SP – On-deck circle diameter	1.52 m	5 ft
FP/SP – On-deck radius	0.76 m	2 ft.6 in
FP/SP – batter's box (each side of home plate)	15.2 cm	6 in
FP/SP – batter's box length	3.13 m	7 ft
FP/SP – batter's box width	0.91 m	3 ft
FP/SP – batter's box front line from centreline of HP	1.22 m	4 ft
FP/SP – coach's box length	4.57 m	15 ft
FP/SP – coach's box distance from 1 st or 3 rd base lines	3.65 m	12 ft
FP/SP – catcher's box length	3.05 m	10 ft



FP = Fastpitch SP = Slowpitch	Metric	Imperial
FP/SP – catcher's box width	2.57 m	8 ft. 5 in
FP/SP – pitcher's circle diameter	4.85 m	16 ft
FP/SP – pitcher's circle radius	2.44 m	8 ft

Equipment measurements/standards

	Metric	Imperial
Pitcher's plate length	61cm	24 in
Pitcher's plate width	15.2cm	6 in
Bat length (no more than)	86.4cm	34 in
Bat diameter (at largest part)	5.7cm	2 ¼ in
Bat weight (not to exceed)	1077.0gm	38 ounces
Bat safety grip length (not less than)	25.4cm	10 in
Bat safety grip length (from knob – not longer than)	38.1cm	15 in
Warm up bat diameter (not less than)	6.4cm	2 ¼ in
Softball (30cm size – min. circumference) 12 inch ball	30.2cm	11 7/8 in
Softball (30cm size – max circumference) 12 inch ball	31.8cm	12 1/8 in
Softball (27cm size – min circumference) 11 inch ball	27.6cm	10 7/8 in
Softball (27cm size – max circumference) 11 inch ball	28.3cm	11 1/8 in
Softball (30cm size – min weight) 12 inch ball	178 gm	6 ¼ oz
Softball (30cm – max weight) 12 inch ball	198.4gm	(7 oz.)
Softball (27cm – min weight) 11 inch ball	166.5 gm	
Softball (27cm – max weight) 11 inch ball	173.6gm	
Home plate – front edge facing pitcher	43.2cm	17 in
Home plate – sides parallel to batter's box	21.6cm	8 ½ in
Home plate – sides pointing towards catcher	30.5cm	12 in
Bases – 1 st base double base	76cm x 38cm	30 x 15 in
Bases – squared at	38.1cm	15 in
Bases – thickness (not more than)	12.7cm	5 in

BATS – Please check to see if the bat you are purchasing for use in Australian competition meets the WBSC bat certification standard. Please visit this direct link:

<https://www.wbcs.org/documents/c/softball-umpire> and click on the Official WBSC approved softball bats list.

NOTE: These bats may have their approval withdrawn if the WBSC finds in additional testing that the bat(s) does (do) not meet the batted ball speed standard (BBS).

Base, plate and batters box measurements

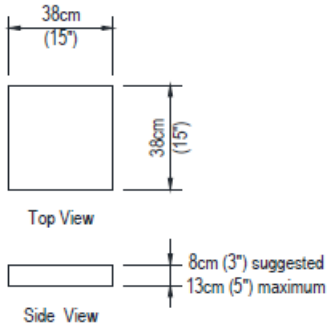

SECOND AND THIRD BASE

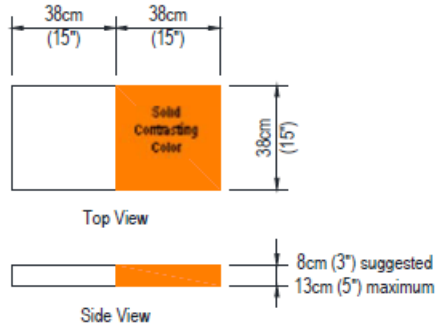

FIRST (DOUBLE) BASE

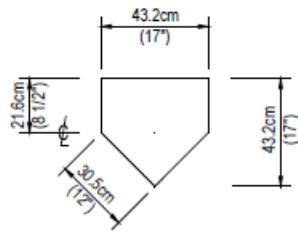

HOMEPLATE

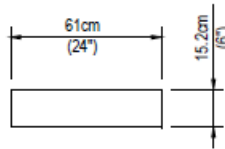

PITCHER'S PLATE

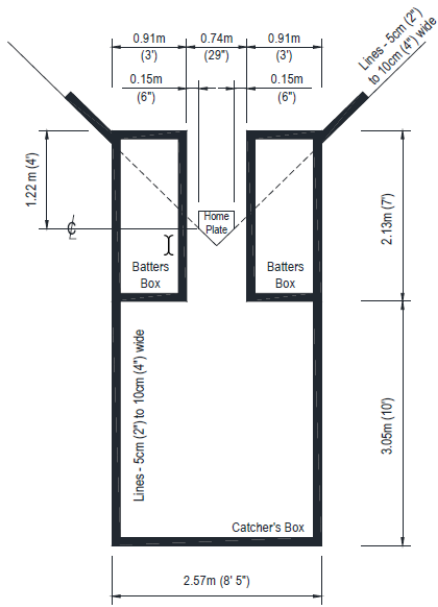

BATTER AND CATCHERS BOX DETAIL



Softball lighting specifications

Produced by Standards Australia

Australian Standard – Guide to sports lighting

Part 2.5: Specific recommendations - Baseball and softball

AS 2560.2.6 – 1994

www.standards.com.au

Please check your local council for lighting standards required for areas other than the Softball diamond.

Diamond upkeep

The priority in field and facility maintenance should be for the safety of the athletes, officials and spectators utilising the grounds. A daily/regular routine check should be made of the facilities by grounds staff, existing or potential hazards should be addressed immediately.

Adequate and constant maintenance is vital to a good field. A field that is neat, well-manicured and well-groomed draws the attention of both teams and spectators. Everyone involved with the game takes pride in a well maintained field. Keeping your fields groomed indicates that you take pride in your facilities, and want to provide a safe, enjoyable softball experience for everyone involved. In addition, keeping your softball field in good shape will save you time and money.

Equipment/tools for diamond maintenance

Dirt dragger:

The piece of equipment that smooths the infield playing surface, usually pulled behind a tractor can be pulled by hand.

Rakes:

Used to sweep and level the base lines and around home plate or pitching area.

Line marker/chalker:

Used to mark the fair lines from home plate to the outfield fence, can be used for batting boxes, pitching circle etc.

Other useful equipment for these areas:

- String for line marker
- Batting box marker
- Shovels & brooms
- Wheelbarrow
- Watering equipment including a hose
- Tarpaulins

Spiker:

A tool used to put pinhole marks in the turf for aeration.

Edger:

A tool used to create a positive clean cut along the turf edge.

Compacter:

A tool used to pack down high stress clay areas such as pitching mounds and home plate.

Materials:

Line marking chalk

Line paint (water – latex –oil)

Fertilisers

Herbicides/pesticides



Suggested safety checklist (performed daily or before games/use)

- 1 Walk the field for broken glass, potholes, exposed or loose base anchors, etc.
- 2 Repair holes in backstops and fences when possible.
- 3 Repair holes and bumps in the infield and outfield.
- 4 Check the condition of home plate and the pitcher's rubber.
- 5 Remove build-up of dirt around bases before dragging.
- 6 Mow as required, avoiding excess turf blade removal.
- 7 Rake and level the infield, especially around sliding areas.
- 8 Check the grandstands and seating areas for any potential hazardous situations (ie worn out or splintered wood, broken benches or seats, unstable chairs, loose stairs, exposed bolts, etc).

Create a high performance skinned infield

- 1 Excavate the infield area
- 2 Match the subgrade to the finish grade contours
- 3 Roll if necessary
- 4 Replace excavated layer with an infield mix. (Refer to [ASTM](#) Standards for the material that should be utilised for skinned areas)
- 5 Use laser-guided equipment to final grade the skin surface to mimic the contouring required for proper surface drainage.
- 6 Apply a suitable topdressing

Clean the infield

Once you've removed the grass from your infield then you'll need to clear off all the little stray grass sections and weeds (cleaning your infield). Cleaning it will best be done by hand with a few people walking all over the dirt portion and picking out all the stray grass and weeds.

Outfield grass

Type:	Santa Ana Couch
Fertilised:	Fortnightly depending on rainfall
Mowed:	2-3 times a week
Watered:	Daily
Aerated:	Monthly
Edged:	Fortnightly

Infield dirt

Composition:	50% Dolerite & 50% Red Brickies Sand
Turned over and Rolled:	Monthly
Dragged:	After each use
Watered:	Before games



Suggested field maintenance routine

Daily maintenance routine before training or use

- Remove tarp from infield (if appropriate)
- Wet down the skinned infield and baselines
- Put out the bases

Daily maintenance routine after training/use

- Cover the base anchor receptacles/holes
- Dragged the skinned infield and baselines
- Recondition the mound, batter's and catcher's box
- Cover the infield with tarp (if appropriate)
- Replace and flatten any loose divots

Game day checklist – field of play

- Remove tarp from infield (if appropriate)
- Mow the grass (if needed)
- Scarify skinned infield with spiker
- Drag smooth
- Water the infield
- Set chalk lines and mark
- Check bases, pitcher's plate and home plate

Game day checklist – operational

- Clean dugouts and remove rubbish
- Check scoreboard (if applicable)
- Check all lights (if night game)
- Check press box and public address system
- Check electrical equipment
- Clean and prepare locker and umpire rooms

Watering the diamond

Proper infield maintenance is virtually impossible without water. Moisture is the key ingredient for a quality infield.

Infield:

Should be watered daily or as often as possible. If the infield is not watered properly, it will become rock hard or powdery. Neither is good for athletes. Water must migrate deeply into the infield soil. Moisture provides your infield with body and holds the soil together resulting in firm footing for the athlete. Weather will dictate how much water is needed to be right at game time (please check with local council if water restrictions are in place).



Turf: Once you have established turf on your field, it is best to irrigate heavily one day a week. This forces roots to seek water down in the soil, resulting in a stronger, deeper root system. Remember – watering immediately after an event will improve turf recuperation. Under severe drought conditions the turf will lose 1cm of water per day. If water penetration is very slow or there is wasteful excess water run-off, it probably is due to soil compaction. Frequent use of aerifying equipment will help to keep soil open and provide needed porosity.

Pitcher's/Batter's Area: because the area around the pitcher's plate and batter's box are constructed with heavy packed dirt/clay, it is necessary to keep them from cracking. Covering the area around your pitcher's plate and home plate after a light watering is the ideal maintenance practice.

Turf maintenance

Athletic traffic is devastating for turf. The constant trampling fields endure cause soils to compact, weakening your turf.

Core-Aerate: Aeration is the most important turf maintenance practice. It helps to loosen compacted soil so air and water can move freely in your root zone. Core-aerate in two directions (avoid doing this in the heat of the day).

Top dress: Top dress means to spread a light material over the turf to fill in low spots and to smooth the playing surface. Top dress the aerated areas at least twice a year, once in the spring and once in the fall.

Over-seed: Over-seed means to place a second seed blend into your turf surface. Every time you aerate and top dress you should take the time to over-seed these areas to strengthen your turf. Select a grass variety with a turf expert.

Mowing patterns: Mowing patterns should be alternated every time your turf is cut. This promotes strong and level turf surfaces by forcing your grass to grow upward rather than falling in a horizontal pattern. The mowing of the outfield grass should be done often enough so that the grass does not grow more than 2.5cm (1") above the desired length. A longer cut may be used on fields that are not being used regularly. The longer cut permits greater photosynthesis, developing stronger, healthier grass.

- 1 Up and down parallel to the right field foul line.
- 2 Up and down parallel to the left field foul line.
- 3 From second base to centre field, back and forth.
- 4 From foul pole to foul pole, back and forth.
- 5 Half circles, same contour as the skinned infield outer edges.

Fertilising: Athletic turf should have an application of complete balanced fertiliser at least once a year, and this should be supplemented by several additional applications of nitrogen during the growing season.



Hot/humid weather grasses thrive best when the complete fertiliser is applied in early spring. Cool weather grasses get more from autumn applications. Some prefer two lighter applications – one in spring and one in autumn (best to check with your local grass expert).

This Guide was produced using the NSW Department of Sport and Recreation's Safe Sports Facilities publication. We acknowledge and thank them for their cooperation in producing this facilities management guide for the Australian softball community.



Document control

Ownership and Approval	
Responsible Officer:	Softball Australia CEO
Approved By:	Softball Australia CEO
Review Frequency:	Annual
Last Reviewed:	November 2020

Version History				
Version	Release Date	Amendment Summary	Author	Approval
1	Feb 2015	Unknown	Chet Gray	CEO Chet Gray
2	Nov 2020	<p>Clause 1.2</p> <ul style="list-style-type: none"> Inserted "Softball Australia and..." Replaced ISF with WBSC <p>Clause 2.12</p> <ul style="list-style-type: none"> AS 2560.1-2002 <p>Clause 2.21</p> <ul style="list-style-type: none"> Removed ISF <p>Equipment measurements/standards</p> <ul style="list-style-type: none"> Included imperial measurement <p>Updated:</p> <p>BATS – Please check to see if the bat you are purchasing for use in Australian competition meets the WBSC bat certification standard. Please visit this direct link:</p> <p>https://www.wbsc.org/documents/c/softball-umpire and click on the Official WBSC approved softball bats list.</p> <p>NOTE: These bats may have their approval withdrawn if the WBSC finds in additional testing that the bat(s) does</p>	Reviewed by Leigh Evans and Chet Gray	CEO David Pryles



Version History				
Version	Release Date	Amendment Summary	Author	Approval
		(do) not meet the batted ball speed standard (BBS).		

Publishing			
Version	Published date	Published by	Published in
V1	Feb 2015	Helen Davis	Website
V2	Nov 2020	Helen Davis	Website